

QUINT-DIODE/48DC/2X20/1X40

Redundancy module

Data sheet
104691_en_01

© PHOENIX CONTACT 2015-01-29



1 Description

Using the redundancy module, it is possible for two power supply units of the same type that are connected in parallel on the output side to increase performance or for redundancy to be isolated from one another.

The reliability of a power supply determines the availability of individual components in a system and whether complex systems can function safely.

Redundant circuits are intended to supply systems that set high demands on operational reliability. Long-term, permanent system availability is ensured by the redundant setup of the power supply.

The power supply of a system can be configured redundantly by switching at least two power supply units in parallel. Together, they then supply the connected devices.

The power supply units involved must be dimensioned to enable the total current requirements of all loads to be covered by one single power supply unit. In the event of an internal device fault or failure of the mains power supply on the primary side, the other device automatically takes over the entire power supply of the loads without interruption.

If the devices connected upstream are QUINT POWER power supply units, redundancy can also be monitored via series connection of the DC-OK relay contacts.

This means that operational reliability of the entire system can be effectively increased.

Features

- Decoupling power supply units switched in parallel
- Installation in potentially explosive areas is permitted
- Load currents up to 60 A are possible
- Easy installation by snapping onto the DIN rail



Make sure you always use the latest documentation.
It can be downloaded from the product at phoenixcontact.net/products.



This data sheet is valid for all products listed on the following page:

2 Table of contents

1 Description 1

2 Table of contents 2

3 Ordering data 3

4 Technical data 4

5 Safety regulations and installation notes..... 7

6 Structure 8

7 Installation 8

8 Mounting position 9

9 Mounting on DIN rails 10

10 Input 10

11 Output..... 10

12 Function..... 11

 12.1 Input..... 11

 12.2 Output 11

 12.3 Temperature response 11

3 Ordering data

Description	Type	Order No.	Pcs. / Pkt.
DIN rail diode module 48 V DC/2x20 A or 1x40 A. Uniform redundancy up to the consumer.	QUINT-DIODE/48DC/2X20/1X40	2320160	1
Accessories	Type	Order No.	Pcs. / Pkt.
Universal wall adapter	UWA 182/52	2938235	1
Assembly adapter for QUINT-PS... power supply on S7-300 rail	QUINT-PS-ADAPTERS7/1	2938196	1
Universal DIN rail adapter	UTA 107/30	2320089	100



Our range of accessories is being continually extended, our current range can be found in the download area.

4 Technical data

Input data/output data	
Nominal input/output voltage	48 V DC
DC input / output voltage range	30 V DC ... 56 V DC
Voltage drop, input/output	0.7 V
Nominal current	2x 20 A (-25 °C ... 60 °C) 1x 40 A (-25 °C ... 60 °C)
Maximum current	2x 30 A (-25 °C ... 40 °C) 1x 60 A (-25 °C ... 40 °C)
Transient surge protection	Varistor
Protection against polarity reversal	Yes, < 120 V
Output current	40 A (Increasing power) 20 A (Redundancy)
Derating	60 °C ... 70 °C (2.5%/K)
Power loss nominal load max.	14 W (I _{OUT} = 20 A)
Efficiency	> 97 %

General data	
Insulation voltage input, output / housing	500 V
MTBF	40000000 h
Mounting position	horizontal DIN rail NS 35, EN 60715
Housing material	Steel sheet, zinc-plated
Dimensions W/H/D	50 mm / 130 mm / 125 mm
Weight	0.75 kg

Security	
Degree of protection	IP20
Protection class	III
SELV	IEC 60950-1 (SELV) and EN 60204 (PELV)

Input connection data	
Connection method	Screw connection
Conductor cross section, solid	0.2 mm ² ... 6 mm ²
Conductor cross section, stranded	0.2 mm ² ... 4 mm ²
Conductor cross section AWG/kcmil	12 ... 10
Stripping length	7 mm
Screw thread	M3
Tightening torque	0.5 Nm ... 0.6 Nm

Output connection data	
Connection method	Screw connection
Conductor cross section, solid	0.5 mm ² ... 16 mm ²
Conductor cross section, stranded	0.5 mm ² ... 16 mm ²
Conductor cross section AWG/kcmil	10
Stripping length	10 mm
Screw thread	M4
Tightening torque	1.2 Nm ... 1.5 Nm

Ambient conditions

Ambient temperature (operation)	-40 °C ... 70 °C (> 60 °C Derating: 2,5 %/K)
Ambient temperature (storage/transport)	-40 °C ... 85 °C
Max. permissible relative humidity (operation)	≤ 95 % (at 25 °C, non-condensing)
Vibration (operation)	< 15 Hz, amplitude ±2.5 mm (according to IEC 60068-2-6) 15 Hz ... 150 Hz, 2.3g, 90 min.
Shock	30g in each direction, according to IEC 60068-2-27
Pollution degree in acc. with EN 50178	2
Climatic class	3K3 (in acc. with EN 60721)

Approvals

ATEX	Ex II 3G Ex nA IIC T4 Gc KEMA 10 ATEX 0165X
IECEX	Ex nA IIC T4 Gc IECEX KEM 10.0091
UL approvals	UL/C-UL listed UL 508 UL/C-UL Recognized UL 60950 UL ANSI/ISA-12.12.01 Class I, Division 2, Groups A, B, C, D (Hazardous Location)



Current approvals/permissions for the product can be found in the download area under phoenixcontact.net/products.

Conformance with EMC Directive 2004/108/EC

Noise immunity according to EN 61000-6-2

Electrostatic discharge	EN 61000-4-2	
	Housing	Level 4
	Contact discharge	8 kV
	Discharge in air	15 kV
	Comments	Criterion A
Electromagnetic HF field	EN 61000-4-3	
	Housing	Level 3
	Frequency range	80 MHz ... 1 GHz
	Frequency range	1 GHz ... 3 GHz
	Comments	Criterion A
Fast transients (burst)	EN 61000-4-4	
	Input	2 kV (level 3 - asymmetrical: conductor to ground)
	Output	2 kV (level 3 - asymmetrical: conductor to ground)
	Comments	Criterion A
Surge current loads (surge)	EN 61000-4-5	
	Input	2 kV (level 3 - asymmetrical: conductor to ground) 1 kV (Level 2 - symmetrical: Conductor to conductor)
	Output	2 kV (level 3 - asymmetrical: conductor to ground) 1 kV (Level 2 - symmetrical: Conductor to conductor)
	Comments	Criterion A
Conducted interference	EN 61000-4-6	
	Input/output	Level 3
	Frequency range	0.15 MHz ... 80 MHz
	Comments	Criterion A

Emitted interference in acc. with EN 61000-6-3

Radio interference voltage in acc. with EN 55011	EN 55011 (EN 55022) Class B, area of application: Industry and residential
Emitted radio interference in acc. with EN 55011	EN 55011 (EN 55022) Class B, area of application: Industry and residential



All technical specifications are nominal values and refer to a room temperature of 25 °C and 70 % relative humidity at 100 m above sea level.

5 Safety regulations and installation notes



DANGER

Never carry out work when voltage is present.



CAUTION:

Before startup please ensure:

All feed lines are sufficiently protected and dimensioned!

All output lines are dimensioned according to the maximum output current of the device or separately protected!

Sufficient convection must be guaranteed.

Do not exceed max. input/output current of 60 A. Use current-limited source, e. g., QUINT POWER or suitable fuse.

The connection must be carried out by a competent person and protection against electric shock guaranteed.

The redundancy module is a device installing into an enclosed space. Installation and start-up may only be carried out by qualified personnel. The relevant country-specific regulations must be observed.

Observe mechanical and thermal limits.

The redundancy module is maintenance-free. Repairs may only be carried out by the manufacturer.



CAUTION:

Installation in zone 2

Observe the specified conditions for use in potentially explosive areas.

Install the device in a suitable approved housing (with at least IP54 protection) that meets the requirements of EN 60079-15.

The device is not designed for use in potentially dust-explosive atmospheres. If dust is present, install the device in suitable, approved housing.

The device must be stopped and immediately removed from the Ex area if it is damaged or was subject to an impermissible load or stored incorrectly or if it malfunctions.

The device is designed for installation in zone 2 potentially explosive areas according to Directive 94/4/EC.

Within a potentially explosive area, the redundancy module is to be connected to the equipotential bonding system via a 35 mm DIN rail (EN 60715).

6 Structure

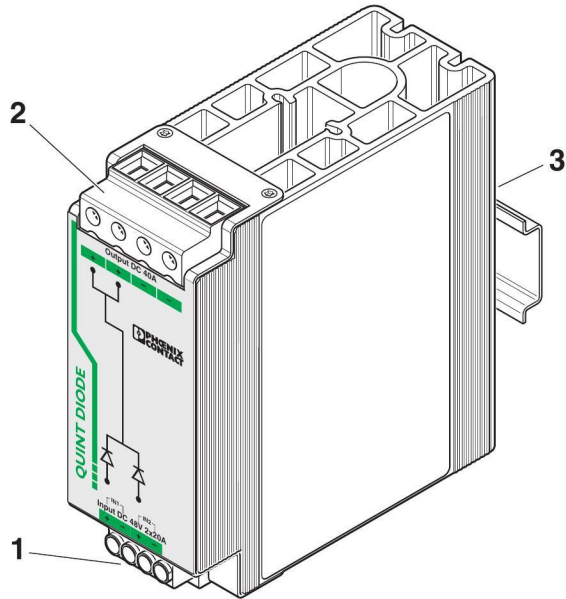

Figure 1 Function elements

- 1 IN1/IN2 DC input:
48 V input voltage, $I_N = 2 \times 20 \text{ A}$
- 2 DC output
- 3 Universal snap-on foot: 35 mm DIN rails according to EN 60715 and panel mounting with UWA 182/52

7 Installation

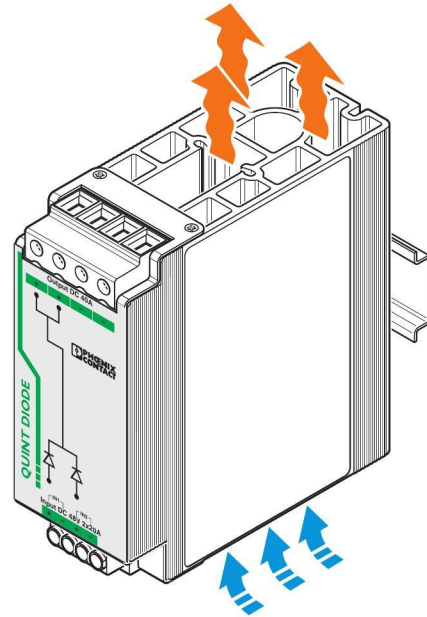

Figure 2 Convection



In order to ensure sufficient convection, we recommend a minimum vertical distance of 50 mm to the other modules. A lateral distance of 5 mm, and in the case of active components, that of 15 mm is necessary for proper functioning of the module. Depending on the ambient temperature and the load of the module, the housing can become very hot.



The module can be snapped onto all DIN rails according to EN 60715 and should be mounted in the normal mounting position (horizontal device orientation, connection terminal blocks on top and bottom).

8 Mounting position

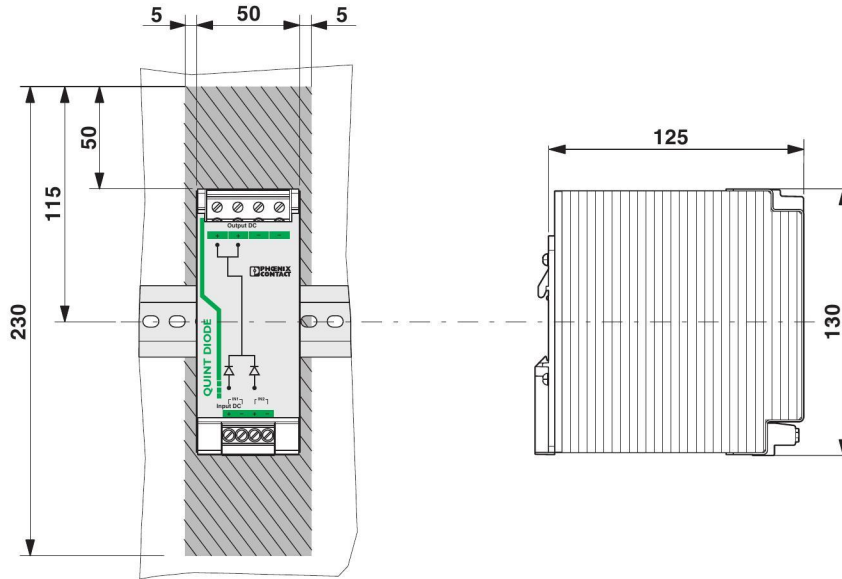

Figure 3 Installation dimensions

Installation depth 125 mm

9 Mounting on DIN rails

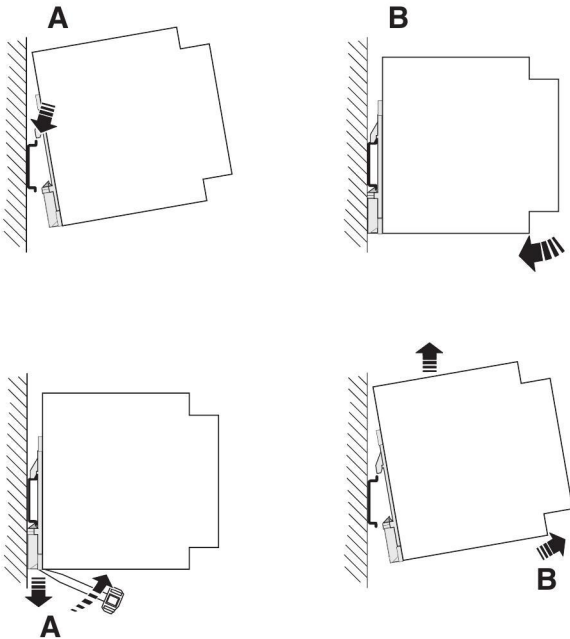

Figure 4 Mounting and removing

Assembly

Position the module with the DIN rail guide on the upper edge of the DIN rail, and snap it in with a downward motion.

Removing

Pull the snap lever open with the aid of a screwdriver and slide the module out at the lower edge of the DIN rail.

10 Input

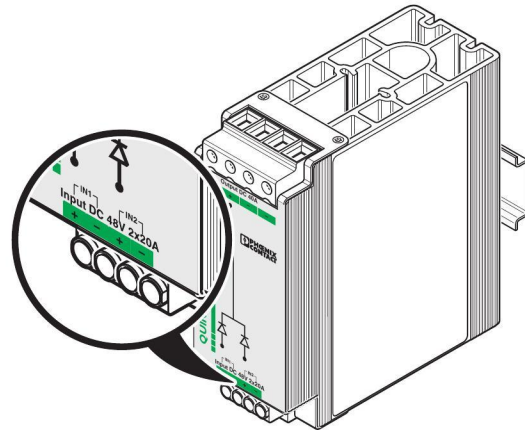

Figure 5 Input

The input voltages are connected via the Input DC +/- screw connections (IN1, IN2).

Use connecting cables of the same length with identical cable cross section for this.

Protection of the primary side

The maximum current for each input is 30 A.

Therefore use a current-limited source (e. g., QUINT POWER) or a suitable fuse.

11 Output

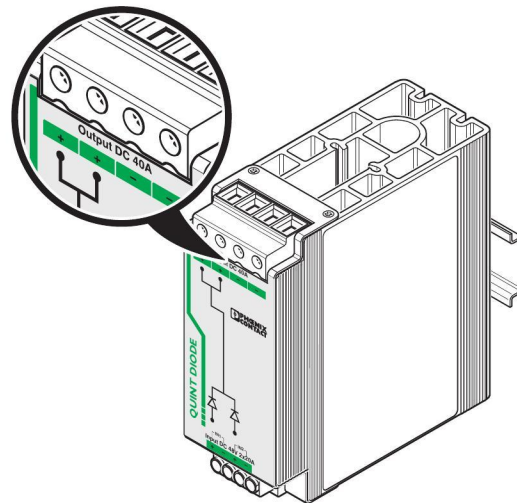

Figure 6 Output

The output voltage is connected via the Output DC +/- and +/- screw connections.

12 Function

12.1 Input

The maximum permissible current depends on the cross section of the connected cables and the ambient temperature.

Conductor cross section	Ambient temperature		
	40 °C	50 °C	60 °C
6 mm ² / 10 AWG	2 x 19 A 1 x 39 A	2 x 18 A 1 x 36 A	2 x 16 A 1 x 32 A
10 mm ² / 8 AWG	2 x 27 A 1 x 54 A	2 x 25 A 1 x 50 A	2 x 21 A 1 x 43 A
16 mm ² / 6 AWG	2 x 30 A 1 x 60 A	2 x 27 A 1 x 55 A	2 x 24 A 1 x 48 A

Only one redundancy module is required for decoupling two power supply units 1 and 2 switched in parallel with nominal currents of up to 20 A.

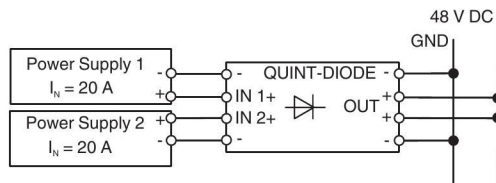

One redundancy module per power supply is required to decouple power supplies with nominal currents from 20 A to 40 A. Inputs 1 and 2 on the redundancy module must be connected to the power supply unit using two conductors. This is necessary because the maximum current carrying capacity of 30 A per input must not be exceeded. To connect the redundancy module to the power supply unit, we recommend using two conductors of the same length and with an identical cross section.

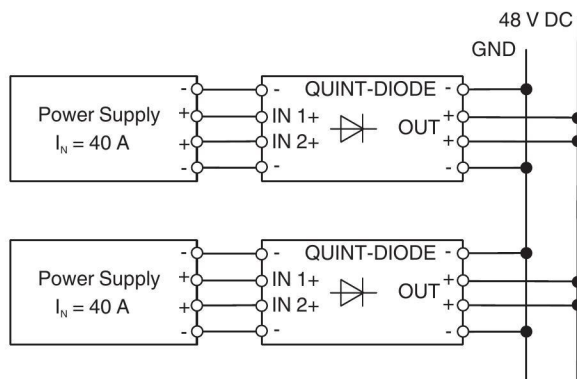

12.2 Output

Only devices suitable for operation in the potentially explosive areas of zone 2 may be connected to the output of the redundancy module in zone 2.

Wire the load with the plus and minus terminals to the output of the redundancy module.

12.3 Temperature response

Horizontal mounting position

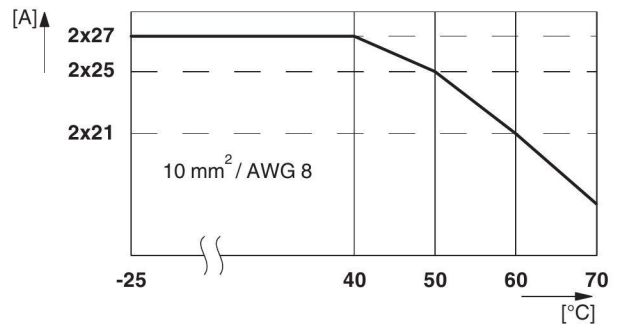

Figure 7 Derating diagram

In the horizontal mounting position (input terminal blocks facing upwards or downwards), the redundancy module can carry current loads up to a maximum of 2 x 27 A or 1 x 54 A at an ambient temperature up to 40 °C. Depending on the ambient temperature, the permissible current carrying capacity is reduced in the case of a conductor cross section of 10 mm².

A maximum of 2 x 21 A or 1 x 43 A can be permanently carried at an ambient temperature of 60 °C.